

# Vorderansicht

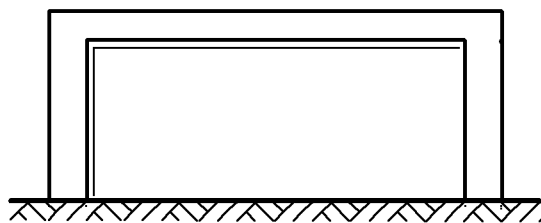

# Längsschnitt

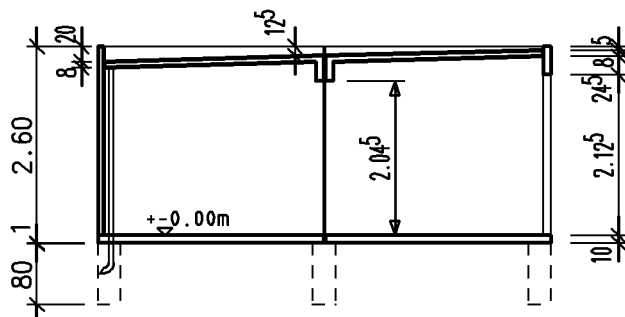

# Fundamente gem. Statik

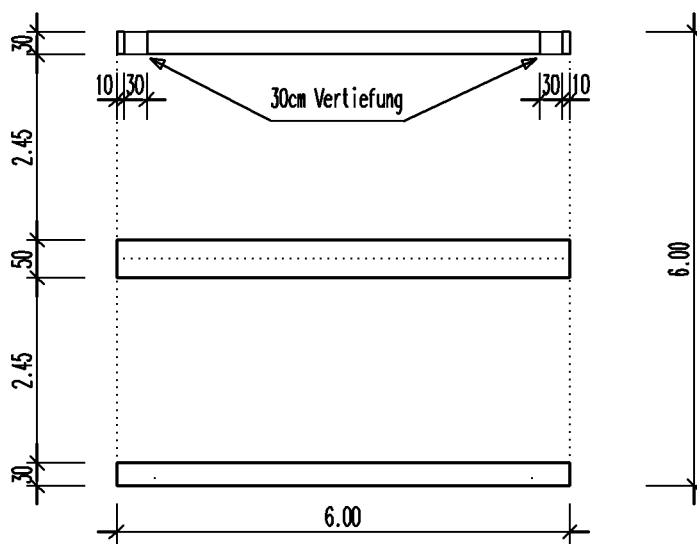

# Grundriss

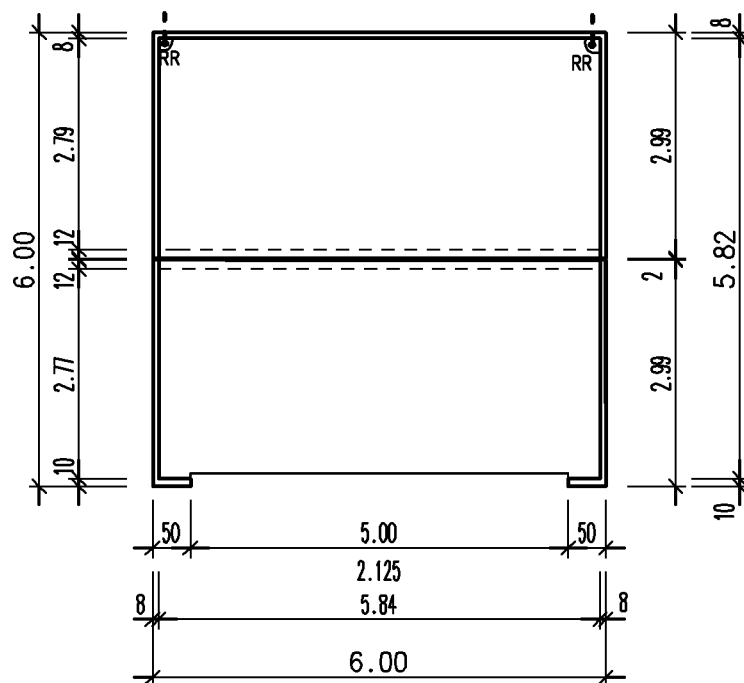

Bauherr

.

Bauvorhaben

.

Auftrag  
Stand: 11/03/04 Dr.

Entwurfsverfasser

Nutzfl. : 33.99 qm  
umb.Raum: 93.60 cbm

Garage Typ K

M. 1:100

tm4-norm