

### Seitenansicht

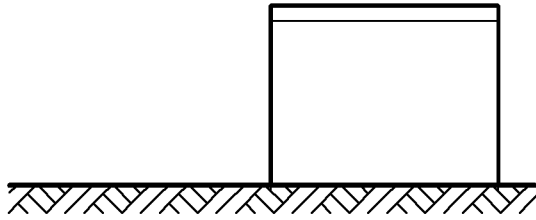

### Längsschnitt

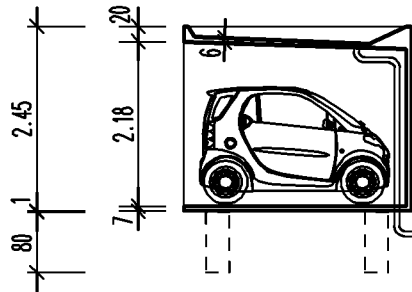

### Vorderansicht

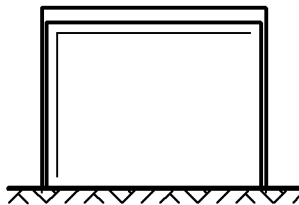

### Querschnitt

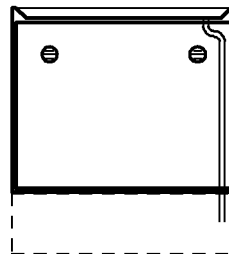

### Grundriss

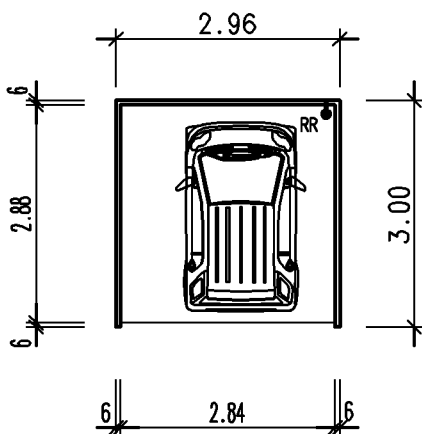

### Gründung gem. Typenstatik

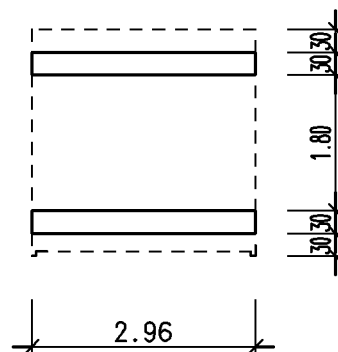

Bauherr

·  
·  
·

Bauvorhaben

·  
·  
·

Stand: 24/11/05 Dr.

Entwurfsverfasser

Nutzfl. : \_\_\_\_\_ qm  
umb.Raum: \_\_\_\_\_ cbm

Anbau

Maßstab 1:100